

EP58 Series

Diameter ø58mm Shaft/Hollow Built-in type Absolute Rotary Encoder

■ Features

- Diameter ø58mm flange type
- Applicable to various mounting environments
- Various output code: BCD, Binary, Gray code (Customizable)
- Various and high resolution(720, 1024 divisions)



■ Applications

- Precision machine tool, Fabric machinery, Robot, Parking system

⚠ Please read "Caution for your safety" in operation manual before using.



■ Ordering information

EP58SC

10

1024

1

R

P

24

Series	Shaft diameter		Resolution/ 1revolution	Output code	Rotating direction	Control output	Power supply
Diameter ø58mm							
SC: Shaft clamping	External	10 ø10mm	Refer to resolution	1 : BCD Code 2 : Binary Code 3 : Gray Code	F: Output value increases at CW direction R: Output value increases at CCW direction ※Shaft based	P:PNP open collector output N:NPN open collector output	5 : 5VDC ±5% 24 : 12-24VDC ±5%
SS: Shaft synchro		6 ø6mm					
HB: Hollow built-in	Inner	8 ø8mm					

※Gray code is customizable.

■ Specifications

Type		Diameter ø58mm absolute rotary encoder							
Resolution		720, 360, 180, 90, 45 division				1024, 512, 256, 128, 64 division			
Electrical specification	Output code		BCD Code	Binary Code	Gray Code		BCD Code	Binary Code	Gray Code
	Output phase/ Output angle	720-division	TS:Signal Pulse (11bit) TS:0.5°±25'	TS:Signal Pulse (10bit) TS:0.5°±25'	TS:Signal Pulse (10bit) TS:1°±25'	1024 division	TS:Signal Pulse (13bit) TS:0.3515°±15'	TS:Signal Pulse (10bit) TS:0.3515°±15'	TS:Signal Pulse (10bit) TS:0.703°±15'
		360-division	TS:Signal Pulse (10bit) TS:1°±25'	TS:Signal Pulse (9bit) TS:1°±25'	TS:Signal Pulse (9bit) TS:2°±25'	512 division	TS:Signal Pulse (11bit) TS:0.703°±15'	TS:Signal Pulse (9bit) TS:0.703°±15'	TS:Signal Pulse (9bit) TS:1.406°±15'
		180-division	TS:Signal Pulse (9bit) TS:2°±25'	TS:Signal Pulse (8bit) TS:2°±25'	TS:Signal Pulse (8bit) TS:4°±25'	256 division	TS:Signal Pulse (10bit) TS:1.406°±15'	TS:Signal Pulse (8bit) TS:1.406°±15'	TS:Signal Pulse (8bit) TS:2.8125°±15'
		90-division	TS:Signal Pulse (8bit) TS:4°±25'	TS:Signal Pulse (7bit) TS:4°±25'	TS:Signal Pulse (7bit) TS:8°±25'	128 division	TS:Signal Pulse (9bit) TS:2.8125°±15'	TS:Signal Pulse (7bit) TS:2.8125°±15'	TS:Signal Pulse (7bit) TS:5.625°±15'
		45-division	TS:Signal Pulse (7bit) TS:8°±25'	TS:Signal Pulse (6bit) TS:8°±25'	TS:Signal Pulse (6bit) TS:16°±25'	64 division	TS:Signal Pulse (7bit) TS:5.625°±15'	TS:Signal Pulse (6bit) TS:5.625°±15'	TS:Signal Pulse (6bit) TS:11.25°±15'
Control output	PNP open collector output NPN open collector output	Output voltage : Min.(Power supply-1.5VDC), Load current : Max. 32mA Load current : Max. 32mA, Residual voltage : Max. 1VDC							
Response time(Rise/Fall)	Ton=800nsec, Toff=Max. 800nsec(Cable : 2m, I sink = 32mA)								
Max. Response frequency	35kHz								
Power supply	• 5VDC ±5%(Ripple P-P : Max. 5%) • 12-24VDC ±5%(Ripple P-P : Max. 5%)								
Current consumption	Max. 100mA(disconnection of the load)								
Insulation resistance	Min. 100MΩ(at 500VDC megger between all terminals and case)								
Dielectric strength	750VAC 50/60Hz for 1 minute(Between all terminals and case)								
Connection	Cable type(Cable gland)								
Mechanical specification	Starting torque	• SC/SS type : Max. 40gf·cm(0.004N·m)				• HB type : Max. 90gf·cm(0.009N·m)			
	Moment of inertia	• SC/SS type : Max. 15g·cm ² (1.5×10 ⁻⁶ kg·m ²)				• HB type : Max. 20g·cm ² (2.0×10 ⁻⁶ kg·m ²)			
Shaft loading	• SC/SS type : Radial : 10kg·f, Thrust : 2.5kg·f • HB type : Radial : 2kg·f, Thrust : 1kg·f								
Max. allowable revolution ^{※1}	3000rpm								
Vibration	1.5mm amplitude or 300m/s ² at frequency of 10 to 55Hz(for 1 min.) in each of X, Y, Z directions for 2 hours								
Shock	Approx. Max. 50G								
Environment	Ambient temperature	-10 to 70°C, storage : -25 to 85°C							
	Ambient humidity	35 to 85%RH, storage : 35 to 90%RH							
Protection	IP50(IEC standard)								
Cable	ø7, 15-wire, Length : 2m, Shield cable (AWG28, Core diameter: 0.08mm, Number of cores: 40, Insulator out diameter: ø0.8)								
Accessories	ø10mm(SC type)/ø6mm(SS type) coupling, Fixing bracket								
Approval	CE								
Unit weight	• Clamping : Approx. 435g • Synchro : Approx. 415g • Built-in : Approx. 410g								

※1: Make sure that. Max response revolution should be lower than or equal to max. allowable revolution when selecting the resolution.

$$[\text{Max. response revolution}(\text{rpm})] = \frac{\text{Max. response frequency}}{\text{Resolution}} \times 60 \text{ sec}$$

※Environment resistance is rated at no freezing or condensation.

ø58mm Shaft/Hollow Built-in Absolute type

■ Output waveform

● 360 division (BCD code output)

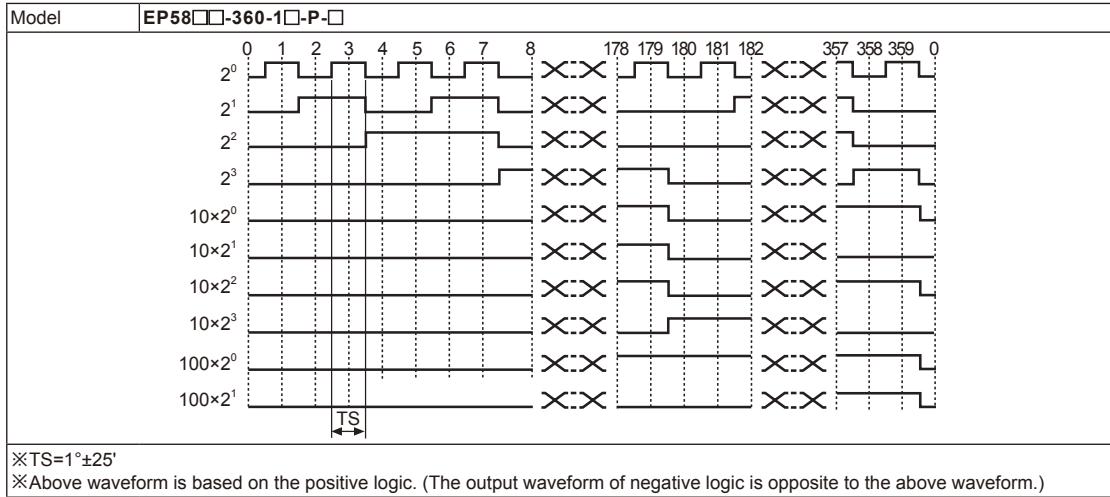

● 360 division (Binary code output)

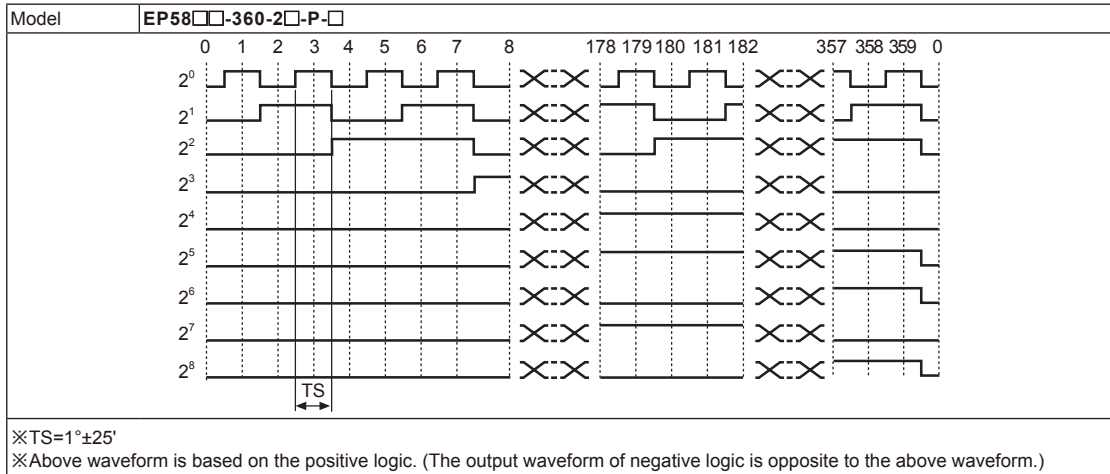

● 1024 division (BCD code output)

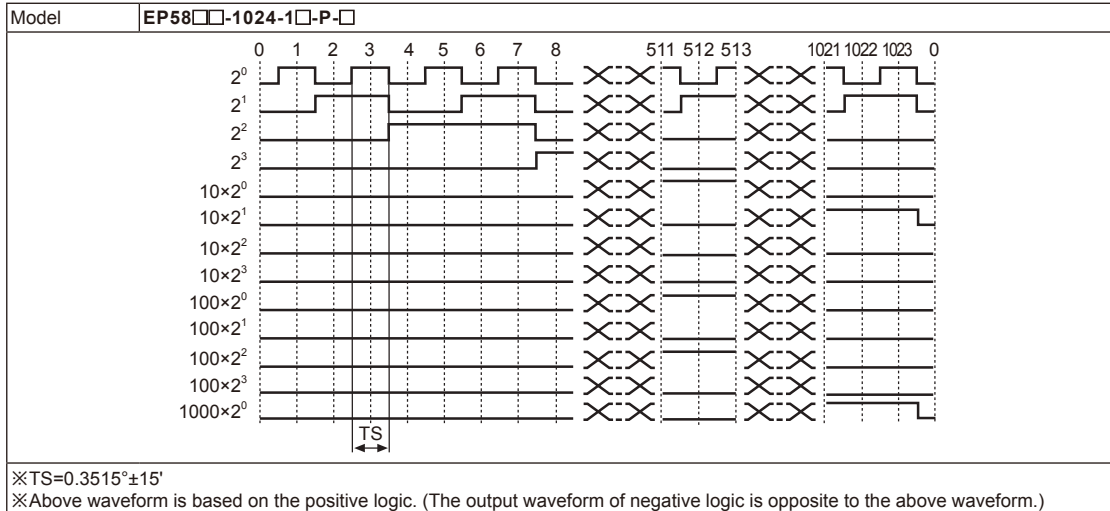

- (A) Photo electric sensor
- (B) Fiber optic sensor
- (C) Door/Area sensor
- (D) Proximity sensor
- (E) Pressure sensor
- (F) Rotary encoder
- (G) Connector/Socket
- (H) Temp. controller
- (I) SSR/ Power controller
- (J) Counter
- (K) Timer
- (L) Panel meter
- (M) Tacho/ Speed/ Pulse meter
- (N) Display unit
- (O) Sensor controller
- (P) Switching mode power supply
- (Q) Stepper motor& Driver&Controller
- (R) Graphic/ Logic panel
- (S) Field network device
- (T) Software
- (U) Other

EP58 Series

Output waveform

1024 division (Binary code output)

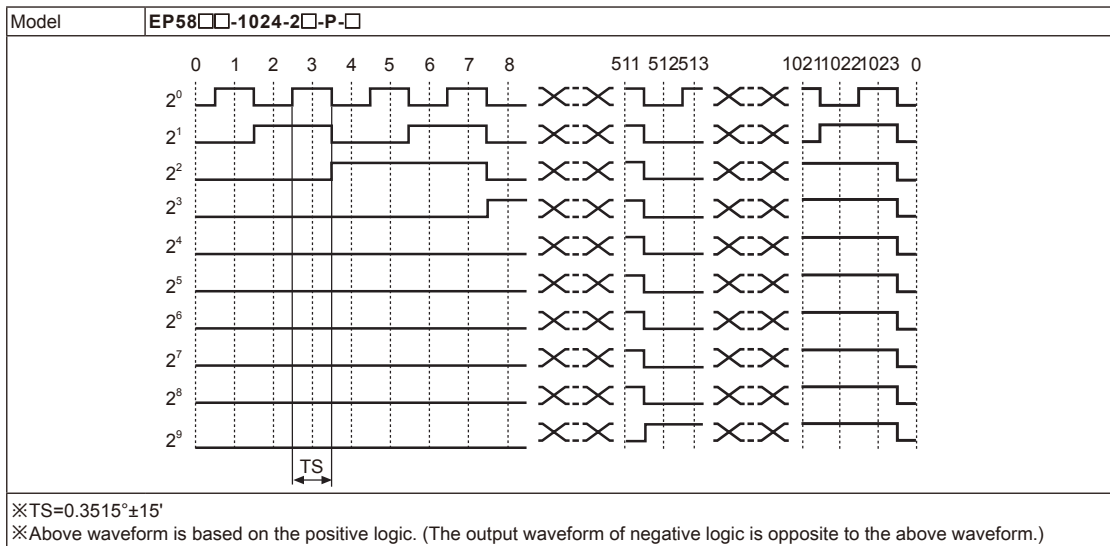

Control output diagram

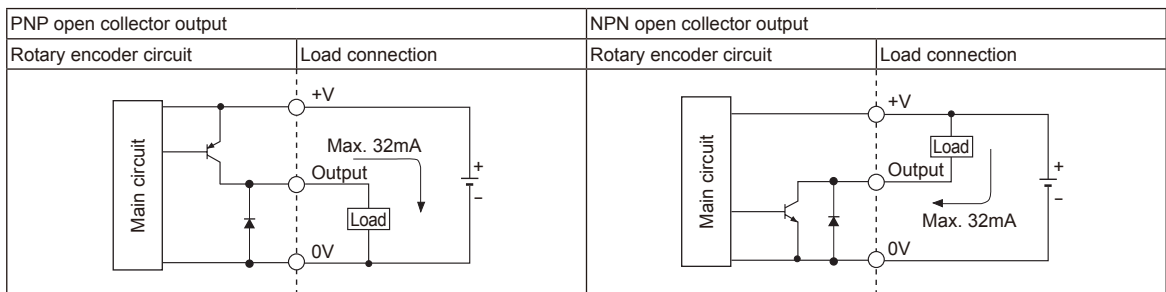

※In case of overload or short on output terminal, it may cause output circuit break.

Connections

BCD Code

Color	Resolution (Division)		
	45-division	48-division	
F.G.	White	+V	
	Black	GND(0V)	
Output wire	Brown	2 ⁰	
	Red	2 ¹	
	Orange	2 ²	
	Yellow	2 ³	
	Blue	(2 ³ ×10)	
	Purple	(2 ¹ ×10)	
	Gray	(2 ² ×10)	
	White/Brown	N-C	2 ³ ×10
	White/Red	N-C	2 ⁰ ×100
	White/Orange	N-C	2 ¹ ×100
	White/Yellow	N-C	2 ² ×100
	White/Blue	N-C	2 ³ ×100
	White/Purple	N-C	2 ⁰ ×1000
Shield wire	F.G.		

Binary Code / Gray Code

Color	Resolution (Division)		
	45-division	48-division	
Power	White	+V	
	Black	GND(0V)	
Output wire	Brown	2 ⁰	
	Red	2 ¹	
	Orange	2 ²	
	Yellow	2 ³	
	Blue	2 ⁴	
	Purple	2 ⁵	
	Gray	N-C	2 ⁶
	White/Brown	N-C	2 ⁷
	White/Red	N-C	2 ⁸
	White/Orange	N-C	2 ⁹
	White/Yellow	N-C	
	White/Blue	N-C	
	White/Purple	N-C	
Shield wire	F.G.		

※Unused wires must be insulated.

※Encoder case and shield wire must be grounded (F.G.).

※N-C : Not connected.

※Output cable must not be short-circuited, because Driver IC is used in output circuit.

ø58mm Shaft/Hollow Built-in Absolute type

■ Dimensions

(unit: mm)

◎ Shaft clamping type

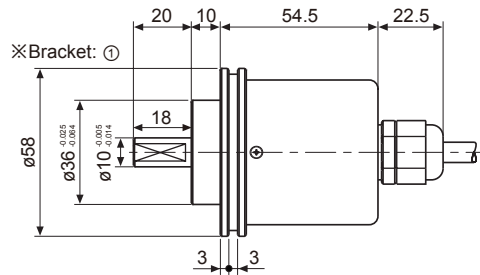
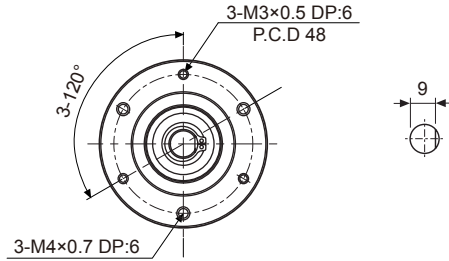

◎ Shaft synchro type

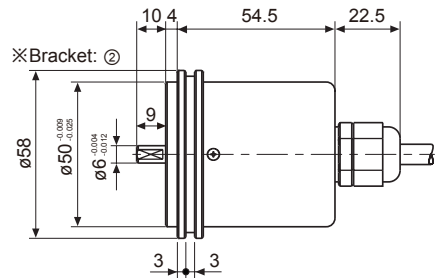
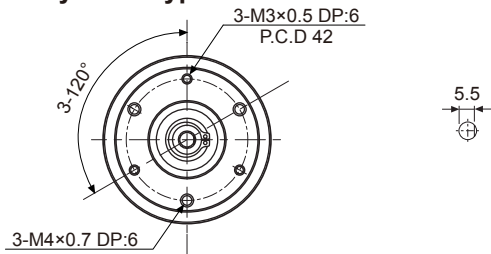

◎ Hollow built-in type

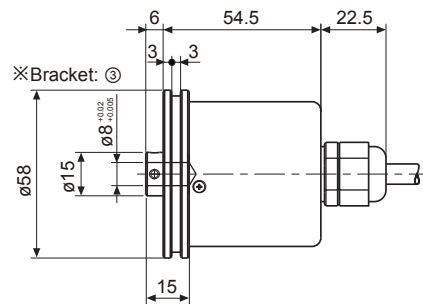
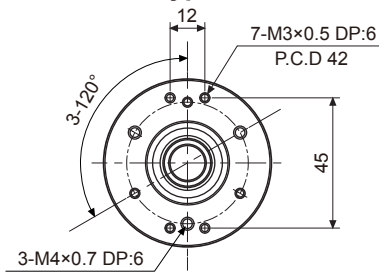

● Bracket

※SC type: ①

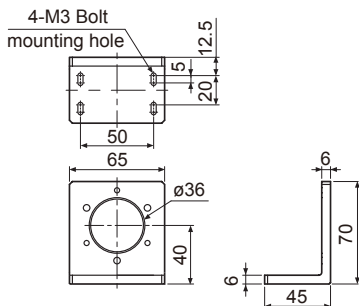

※SS type: ②

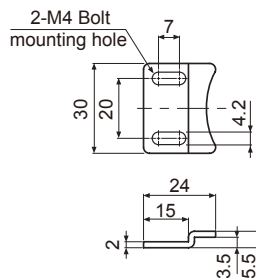

※HB/H type: ③

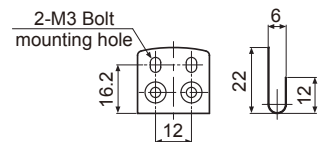

● ø10 Coupling(EP58SC10 Series)

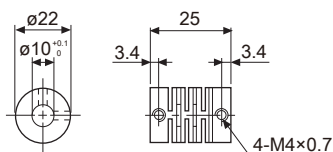

● ø6 Coupling(EP58SS6 Series)

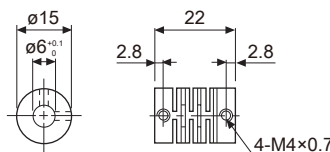

- Parallel misalignment: Max. 0.25mm
- Angular misalignment: Max. 5°
- End-play: Max. 0.2mm
- ※ For parallel misalignment, angular misalignment, End-play terms, refer to the F-78 page.
- ※ For flexible coupling(ERB Series) information, refer to the F-71 page.

(A)	Photo electric sensor
(B)	Fiber optic sensor
(C)	Door/Area sensor
(D)	Proximity sensor
(E)	Pressure sensor
(F)	Rotary encoder
(G)	Connector/Socket
(H)	Temp. controller
(I)	SSR/Power controller
(J)	Counter
(K)	Timer
(L)	Panel meter
(M)	Tacho/Speed/ Pulse meter
(N)	Display unit
(O)	Sensor controller
(P)	Switching mode power supply
(Q)	Stepper motor& Driver&Controller
(R)	Graphic/Logic panel
(S)	Field network device
(T)	Software
(U)	Other